

CHEN5012

**“SIMULATION AND ECONOMIC OPTIMIZATION OF NATURAL GAS
LIQUEFACTION PROCESSES”**

HERBERT JHORDY MANRIQUE OLORTEGUI

19027836

Supervisor: Prof/Dr

RANJEET UTIKAR

The final report submitted as requirement
for the degree of Master of Engineering in
Chemical Engineering (Honours)

Discipline of Chemical Engineering

Curtin University

2019

To the best of my knowledge and belief, this report contains no material previously published by any other person except where due acknowledgement has been made. This report contains no material which has been accepted for the award of any other degree or diploma in any university.

Signature :

Name : HERBERT JHORDY MANRIQUE OLORTEGUI

Date : 07/06/2019

ACKNOWLEDGEMENTS

Firstly, I would like to express my sincere gratitude to my supervisor Prof. Ranjeet Utikar, for the continuous support of my Master study during this last semester, for his patience and immense knowledge. His guidance helped me in all the time of research and writing of this report.

Besides my advisor, I would like to thank my lovely family for their constant emotional support and immeasurable love, especially to my father, who is the wisest person I have ever met.

Finally, my sincere thanks also go to the Peruvian Government represented by the government institution PRONABEC, which gave me the financial support during my postgrad studies in Australia.

ABSTRACT

The propane precooled mixed refrigerant (C3MR) process is the most used technology for liquefying natural gas and has been widely studied. For large scale LNG plants, the mixed fluid cascade (MFC) process is emerging as a novel solution and needs to be thoroughly investigated. There is limited data on the economic aspects, and energy consumption of MFC, as well as its performance in comparison with C3MR. Several operating and design parameters govern the performance of the liquefaction process, and careful optimization is required. This work presents a thorough comparison between the C3MR process and the MFC process. Aspen Hysys is used to simulate the processes under the same conditions of precooling, liquefaction and subcooling. The process operating and design conditions are further optimized using the genetic algorithm. The objective functions employed for the optimization consider the equipment cost (CAPEX) and the operating cost (OPEX) for a more representative solution. Finally, energy consumption, capital cost, operating cost and annual cost are discussed, selecting the most suitable process for the natural gas feed analysed.

TABLE OF CONTENTS

INTRODUCTION.....	1
1.1. Background.....	1
1.2. Objectives	2
1.3. Significances.....	3
1.4. Scope of the study.....	3
1.5. Layout of the report	3
LITERATURE REVIEW.....	5
RESEARCH METHODOLOGY	9
3.1. Processes Description	9
3.1.1. C3MR – Propane Precooled Mixed Refrigerant Process.....	9
3.1.2. MFC – Mixed Fluid Cascade Process.....	10
3.2. Processes Modelling	11
3.3. Economic Modelling	12
3.3.1 Equipment Costs Estimation:.....	12
3.3.2. CAPEX	13
3.3.3. OPEX	14
OPTIMIZATION	16
4.1. Method.....	16
4.2. Constraints	17
4.3. Optimization Objectives	18
RESULTS AND DISCUSSION	19
5.1. C3MR Process	19
5.2. MFC Process.....	22
5.3. Processes Comparison	25
CONCLUSIONS AND RECOMMENDATIONS.....	28
REFERENCES.....	30
APPENDICES.....	32
APPENDIX 1: VBA Macro for C3MR process.....	32
APPENDIX 2: VBA Macro for MFC process – Subcooling Loop.....	34
APPENDIX 3: VBA Macro for MFC process – Liquefaction Loop	35
APPENDIX 4: VBA Macro for MFC process – Precooling Loop.....	36
APPENDIX 5: MATLAB™ functions for equipment costing	37

APPENDIX 6: MATLAB™ functions for Hysys Link via VBA	38
APPENDIX 7: MATLAB™ optimization functions for C3MR.....	39
APPENDIX 8: MATLAB™ optimization functions for MFC	41

LIST OF FIGURES

Figure 1 – C3MR process flowsheet	10
Figure 2 – MFC process flowsheet	11
Figure 3 – Communication scheme for optimization of C3MR (a) and MFC (b) processes ...	17
Figure 4 – C3MR and MFC Objective Functions Comparison	26
Figure 5 – C3MR Composite Curves	27
Figure 6 – MFC Composite Curves	27

LIST OF TABLES

Table 1 – Natural gas feed composition.....	11
Table 2 – Refrigerant compositions for base-case flowsheets	12
Table 3 – Tuning parameters for genetic algorithm	16
Table 4 – Base Case and Best Individuals for each Objective Function, C3MR process.....	19
Table 5 – Optimization Results for C3MR process	20
Table 6 – Equipment Purchase Cost for C3MR process	21
Table 7 – Economic Results for C3MR process	22
Table 8 – Base Case and Best Individuals for each Objective Function, MFC process	23
Table 9 – Optimization Results for MFC process	24
Table 10 – Equipment Purchase Cost for MFC process	25
Table 11 – Economic Results for MFC process.....	25

NOMENCLATURE

C3MR:	Propane Precooled Mixed Refrigerant Process
CAPEX:	Capital Expenditure, defined in equation (3)
HHV:	Gross Heating Value of Natural Gas
HPA:	Hours per Annum
LNG:	Liquefied Natural Gas
LR:	Liquefaction Refrigerant used in MFC process
MBTU:	Millions of BTU
MCHX:	Main Cryogenic Heat Exchanger, simulated as two LNG exchangers
MFC:	Mixed Fluid Cascade Process
MR:	Mixed Refrigerant used in C3MR process
MTPA:	Millions of tonnes per annum
MUSD:	Millions of Dollars
MUSD/y:	Millions of Dollars per Year
OPEX:	Operating Expenditure, defined in equation (5)
PR:	Precooling Refrigerant used in MFC process
SR:	Subcooling Refrigerant used in MFC process
TAC:	Total Annualized Cost, defined in equation (6)
UA:	Effective Area (kW/°C)
VBA:	Visual Basic for Applications

CHAPTER 1

INTRODUCTION

1.1. Background

Natural Gas is the cleanest-burning fossil fuel due to the less carbon dioxide emissions compared to other fossil fuels such as diesel or gasoline. This fuel can be transported by pipelines when the distance is relatively short or as liquefied natural gas (LNG) for further distances; however, the reserves of natural gas should justify the significant investment required for the construction of a natural gas liquefaction plant (Kidnay, Parrish and McCartney 2011). According to the last BP Statistical Review of World Energy 2018 (BP 2018), the global LNG exports has reached 393.4 billion cubic meters in 2017 which represents an increment of 10% higher compared to 2016, and it is expected that this number will continue to increase in the future.

The LNG is a cryogenic liquid which is produced to transport vast amounts of natural gas in a relatively small volume because its density is approximately 600 times higher than average natural gas density. Many technologies for liquefaction are available to reach low liquefaction temperatures (-160°C) and large plant capacities which were roughly classified by (Jensen 2008) based on the refrigerant used in:

1. Pure Fluid Cascade Process: All refrigerants are pure components, but many cycles are used to improve thermodynamic efficiency. The Optimized Cascade Process licenced by ConocoPhillips is in this category.
2. Mixed Fluid Refrigerant: The refrigerants are mixes of light hydrocarbons (methane, ethane, ethylene, propane, n-butane or i-butane) and nitrogen whose composition is set to match the cooling curve of natural gas. The Single Mixed Refrigerant Process or PRICO process, The Korea Single Mixed Refrigerant Process by Korea Gas Corporation, The Propane-precooled Mixed Refrigerant Process licenced by Air Products and Chemicals and the Dual Mixed Refrigerant Process are in this category.

3. Mixed Fluid Cascade Process: Combination of the two processes mentioned before that increases the efficiency matching the natural gas cooling curve in each refrigerant loop. The Mixed Fluid Cascade Process licenced by Statoil/Linde is in this category.

Although all these processes are different in equipment configuration and are selected principally depending on the liquefaction train capacity required, all of them need large amounts of energy for the compression and, according to (Usama, Sherine and Shuhaimi 2011), represent approximately 30-40% of the capital investment of the overall plant.

(Austbø, Løvseth and Gundersen 2014) did a review of the literature related to the optimization in LNG process design and operation and found that the most studied LNG process technologies were the single mixed refrigerant and the propane precooled mixed refrigerant, and the most employed optimization function was minimum power or utility consumption. More recent reviews, such as those done by (Qyyum, Qadeer and Lee 2018) and (Lee, Park and Moon 2018), reported similar results. Only a few papers reported optimizations using capital and operating costs functions simultaneously.

A novel large-scale technology for natural gas liquefaction is the Mixed Fluid Cascade Process (MFC) licensed by Statoil/Linde, which was used in the Snohvit LNG project. This process has higher efficiency compared to optimized cascade because it uses mixed refrigerants in each refrigerant loop instead of pure refrigerant as in optimized cascade technology; however, the design is much more complicated due to refrigerant composition degrees of freedom. From the literature reviewed in section 2, it can be said that there is an evident lack of studies for optimizing alternative processes, such as mixed fluid cascade, which use an optimization function that includes economic aspects and power consumption simultaneously.

1.2. Objectives

The general objective for the present research is to make a fair comparison considering capital costs and operating costs between two technologies for the liquefaction of natural gas, the propane precooled mixed refrigerant C3MR and the mixed fluid cascade MFC, where the former is the most employed technology nowadays for liquefaction and the latter represents a relatively new process for large-scale LNG plants.

The specific objectives include the following:

- To simulate both processes under real operational conditions based on the information available in the literature.
- To develop an analytical methodology for estimating the capital and operating costs of both processes.
- To optimize the processes to obtain operational conditions for low capital costs and operating costs.

1.3. Significances

The liquefaction of natural gas involves significant amounts of energy and evaluating new alternatives that allow saving energy and money have been a major issue these years. To help to fill this gap, the present study model a relatively novel and not enough examined technology for the liquefaction and make a fair comparison with the widely studied C3MR liquefaction processes working with objective functions that consider capital and operating costs simultaneously.

1.4. Scope of the study

The present work analyses and compares two technologies for natural gas liquefaction, the C3MR and the MFC, focused only on the liquefaction train (natural gas precooling, liquefaction and subcooling). Both processes are simulated in Aspen Hysys using the same feed and conditions of precooling and subcooling.

1.5. Layout of the report

This report is divided into 6 chapters and 8 appendices. The first chapter, INTRODUCTION, details the background, objectives, significances and the scope of the present work. The second chapter, LITERATURE REVIEW, summarises and analyses the previous works done in LNG process modelling and optimization to identify gaps remaining in this subject. The third chapter, RESEARCH METHODOLOGY, describes both processes and states the general conditions that the simulations must satisfy, explains the steps followed to cost all the equipment involved in the liquefaction. The fourth chapter, OPTIMIZATION, define the method, the parameters

and the constraints before performing the optimization. The fifth chapter, RESULTS AND DISCUSSION, compares the results of the process optimizations and discusses the main reasons for the differences. The sixth chapter, CONCLUSIONS, respond to the problem and the objectives stated in section 1. Finally, the appendices detail all the codes used in visual basic for applications (VBA) and MATLABTM during to carry out the optimization.

CHAPTER 2

LITERATURE REVIEW

Many authors have studied the optimal conditions for several LNG processes during the past few years. The Single Mixed Refrigerant (SMR) or PRICO process was one of the most studied LNG processes due to its relative simplicity and the limited number of process variables. One of the first studies focused on simulation and optimization of LNG processes was made by (Jensen and Skogestad 2006), who evaluated the optimal operation of the PRICO process showing the main difference between design and operation optimization, where the former considers the minimum temperature approach in heat exchangers as the principal design variable while the latter already has a maximum design area which cannot be exceeded during the operation. They reduced 2.6% the energy consumption in an “optimal design” scenario optimizing the operational conditions.

(Wahl, Løvseth and Mølnvik 2013) studied the PRICO process using sequential quadratic programming and compare their results to (Jensen and Skogestad 2006) and other publications to show the saving in time that can be gained employing this optimization method. The objective function was the compressor energy and the typical execution time was 4 minutes and, therefore, this technique resulted in a significant reduction in solution time optimizing a simple process, however, more complex problems should be solved using both gradients based and other routines. The review done by (Austbø, Løvseth and Gundersen 2014) suggested that PRICO process was geared towards offshore LNG plants due to the limited area capacity available.

Another well studied technology in the literature is the Propane Precooled Mixed Refrigerant Process or C3MR, (Taleshbahrami and Saffari 2010) performed the thermodynamic simulation and optimization of this process in MATLABTM using Peng-Robinson equation of state. The goal of the work was to minimise the power consumption through the approach of the composite curves in the heat exchangers. They validated their model Aspen Hysys and optimized it using the genetic algorithm, obtaining a 23% less power than the base design.

(Wang, Zhang and Xu 2012) developed a new methodology for the minimisation of energy consumption in LNG processes based on thermodynamic analysis, mathematical programming and rigorous simulation, and the C3MR process was taken as a model for testing this new

methodology. To reduce the complexity of the algorithm, some thermodynamic properties were regressed under specific operational range and redundant variables were omitted. The process was programmed in GAMS and then solved by LINDOGlobal solver. Finally, the results were compared with a simulation made in Aspen plus to validate the model. As a result, the energy consumption was reduced by 13%; however, the mixed refrigerant composition was not considered as a variable in the optimization.

(Sanavandi and Ziabasharhagh 2016) optimized the C3MR process using the specific energy consumption as the objective function. Since the mixed refrigerant composition has a high impact on the specific energy consumption, it was optimized using Hysys optimizer functions and an empirical method. After the optimization with both procedures, it was claimed that the results were not practical in a real LNG plant because the degree of precision; therefore, they relaxed the variable constraints (pressure, temperature and mol percentage composition of the mixed refrigerant) using amounts that can be controlled, reaching a 5.35% of specific energy consumption saving in the final scenario.

In addition to C3MR, the Pure Cascade process and Mixed Fluid Cascade (MFC) process are also designed for large-scale LNG plants, (Fahmy, Nabih and El-Nigeily 2016) enhanced the Pure Cascade Process changing the J-T valves in refrigerant loops for expanders which can recover some shaft work. They tested the expanders in several places in the process and could reduce the power consumption by 5%; the plant could reach 92% of thermal efficiency and increased the LNG production by 7%. They also did a small economic assessment reporting a relatively short payback period for the optimal case.

(Pereira and Lequisiga 2014) compared the C3MR and the Cascade process for the potential Timor LNG plant to be built in Timor-Leste. In the simulations carried out, they found that the shaft work required for the cascade process was 69% less than for the C3MR process; however, the C3MR process showed more LNG production and plant profit. They recommended the C3MR process and suggested further studies considering the type of refrigerant, capital cost, driver availability, heat exchanger types and surface area available.

(Eiksund, Brodal and Jackson 2018) optimized the pure Cascade Process presenting a systematic study where the number of compressors and heat exchanger were not constrained. They gave optimal designs for different pressure levels and compared the energy consumption

in each scenario to finally show that 11 pressure levels are required for a pure-component cascade scheme to equal the energy efficiency of a Mixed Fluid Cascade with 3 refrigerants. Although the improvement in the design and energy consumption, the trade-off between capital and the operating cost was not analysed.

The Mixed Fluid Cascade Process (MFC) licensed by Statoil/Linde is relatively new and was used in the Snohvit LNG project. This process has higher efficiency compared to optimized cascade because it uses mixed refrigerant in each refrigerant loop instead of pure refrigerant as in optimized cascade technology; however, the design is much more complex due to refrigerant composition degrees of freedom in each loop. (Ding et al. 2017) modelled the MFC process in Aspen Hysys and analysed the effects of the gas natural inlet pressure, LNG storage pressure, water-cooler outlet temperature and mixed refrigerant compositions in each loop on the specific power consumption obtaining general trends for each parameter. Then, they performed the optimization using the genetic algorithm method in MATLABTM considering the specific power consumption as an objective function. After reducing the specific power consumption in 13.15% less than their base case, they modified the process configuration, adding some pressure levels or separators in each cooling loop. They finally reported that having three pressure levels in the precooling loop, and one pressure level in liquefaction and subcooling loop produced the optimal conditions of the process.

Other studies have also considered economic aspects of the design, (Hatcher, Khalilpour and Abbas 2012) proposed eight objective functions for optimizing LNG processes, four oriented to operational aspects and rest oriented to design aspect. They tested the eight functions using the C3MR process modelled in Aspen Hysys as base flowsheet and the robust “BOX” method included in the software. They reported that the minimization of the compression work was the most effective function from the operational aspects point of view; and for the design aspects, minimizing the net present value (NVP) is more suitable when there is no area available restriction while minimizing ($W_s - UA$) is preferred when a limitation in the area is imposed.

The work presented by (Wang, Khalilpour and Abbas 2014) analysed the C3MR and the Dual Mixed Refrigerant (DMR) processes for a mid-scale production of 3MTPA of LNG and used four objective functions that considered capital and operating costs: total shaft work consumption, total cost investment, total annualized cost and total capital cost of compressors and MCHEs. The objectives were tested using Hysys Optimizer and Peng-Robinson fluid

package. Although they got 44.5% and 48.6% reduction in total shaft work consumption for C3MR and DMR, respectively minimising only total shaft work consumption, the UA values for heat exchangers were infinitely large. They reported that the best objective function that reduces both shaft work and UA values was the total capital cost of compressors and MCHEs; reducing 14.5% and 26.7% the specific power consumption at low UA values.

(Lee and Moon 2016) performed the total cost optimization of the SMR process (1MTPA of LNG plant capacity) considering the equipment cost. In the research, they compared two objective functions: the first one, the total energy required by the compressors and pumps, and the second one, the total annualized cost of the process (CAPEX + OPEX). They run the objectives using gPROMS for process modelling and the successive reduced quadratic programming (SRQPD) solver for optimization, they got a slightly similar reduction of total shaft work, 17.7% and 16.5% for first and second objective functions respectively; however, the total capital cost decreased 28.3% employing the total annualized cost as objective function. Although the area of the heat exchanger was not mentioned in this work, this value increased in both optimizations based on the capital cost reported for the heat exchanger compared to the base case.

(Lee and Moon 2017) developed a profit optimization of the DMR process (1MTPA of LNG capacity) considering the liquefaction extraction rate and the boil-off gas. The basis of the model is that a fraction of natural gas from the wells and the boil-off gas are used for generating the power required by the liquefaction. In addition, to maximise the plant profit, they also studied the energy required by the process and the total annualized cost of the process. Using gPROMS and SRQPD for modelling and optimization respectively, they found that the optimal solution occurred when all the energy required came from the boil-off gas, reducing the energy requirement by 38.6% and increasing the annual profit by 22.5%.

From this review, it can be clearly seen that not enough papers have worked optimizing capital and operating costs simultaneously for a relatively new process such as the MFC process. New LNG plants that will be constructed in the next years should compare these processes available, and an economic comparison with the most-used LNG process C3MR would help for a better making decision.

CHAPTER 3

RESEARCH METHODOLOGY

3.1. Processes Description

3.1.1. C3MR – Propane Precooled Mixed Refrigerant Process

The C3MR process (Figure 1) consists in a precooling train which uses propane to cool down the natural (green flow) gas and the mixed refrigerant (magenta flow) to -35°C followed by the Main Cryogenic Heat Exchanger (MCHX) where the natural gas is liquefied and sub-cooled to -160°C . The propane (black flow) in the precooling train is split and expanded in branches at different pressure levels to provide the cooling needed by the natural gas and the mixed refrigerant (MR), then is recompressed in three stages to be condensed and expanded again. The MR, which is a mixture of methane, ethylene, propane and nitrogen, is separated in liquid and vapour phase after exiting the propane precooling. Both, the vapour and the liquid MR enter the MCHX and are liquefied and sub-cooled along with this unit. The vapour MR leaves LNG-101 and is expanded before re-entering to the top of this unit, providing the cooling for LNG-101. The liquid MR exits the LNG-100 after reducing its temperature and is expanded before being mixed with the vapour MR from LNG-101 to enter LNG-100 providing the cooling for LNG-10 finally. Finally, the MR is recompressed and cooled by water before passing through the propane precooling train.

During the C3MR process modelling in Aspen Hysys, six shell-and-tube heat exchangers, three compressors and one cooler are used for the propane train. The propane pressures after each expansion were selected based on the natural gas and MR intermediate temperature requirement, and these intermediate temperatures are equal for the natural gas and the MR to finally reach -35°C just before entering MCHX. Two multi-streams heat exchangers are used for modelling the MCHX, the temperatures for all hot streams are equal after leaving each LNG exchanger and the temperature of the cold stream is set at least 3°C below the outlet hot stream temperature for a reasonable temperature approach. Pressures of liquid MR and vapour MR are equal after their expansions and, finally, the MR leaving the MCHX is re-compressed, condensed and further cooled by the propane cycle.

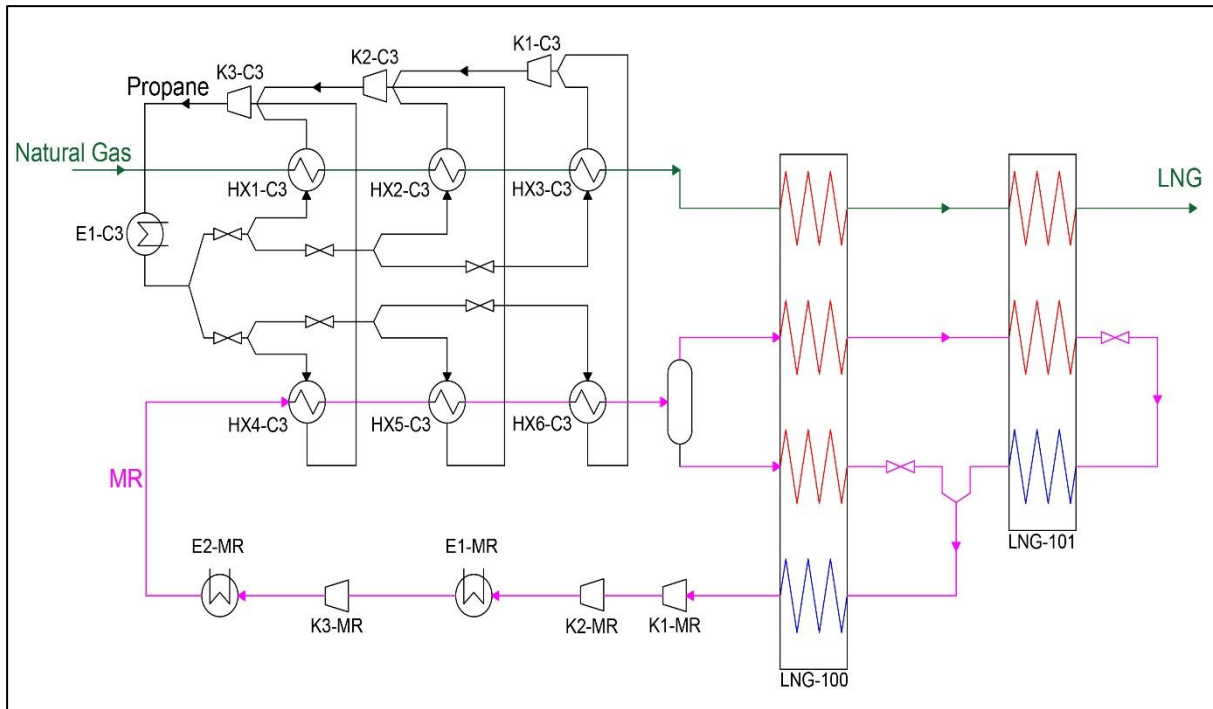

Figure 1 – C3MR process flowsheet

3.1.2. MFC – Mixed Fluid Cascade Process

The MFC process (Figure 2) has three refrigerant loops for precooling (black flow), liquefaction (orange flow) and subcooling (light blue flow), respectively. Each circuit employs different refrigerant compositions for a better temperature approach between hot and cold composites. In the precooling loop, the refrigerant is a mixture of ethylene, propane and n-butane and has two compressors and two coolers. In the liquefaction loop, the refrigerant is a mixture of methane, ethylene and propane and presents two compressors and one cooler. Finally, the subcooling loop refrigerant contains nitrogen, methane and ethylene and has three compressors due to more considerable pressures and one cooler.

In the MFC process modelling, the all hot stream temperatures leaving each LNG exchanger are the same and equal to -35°C , -76.12°C and -160°C respectively. Cold stream temperatures are at least 3°C lower than the hot streams for a reasonable temperature approach. Refrigerant flowrates are calculated based on hot streams, from subcooling loop to precooling loop, since subcooling refrigerant is determined by the natural gas cooling required, liquefaction refrigerant depends on the subcooling refrigerant and the natural gas, and precooling refrigerant depends on the all three mentioned before.

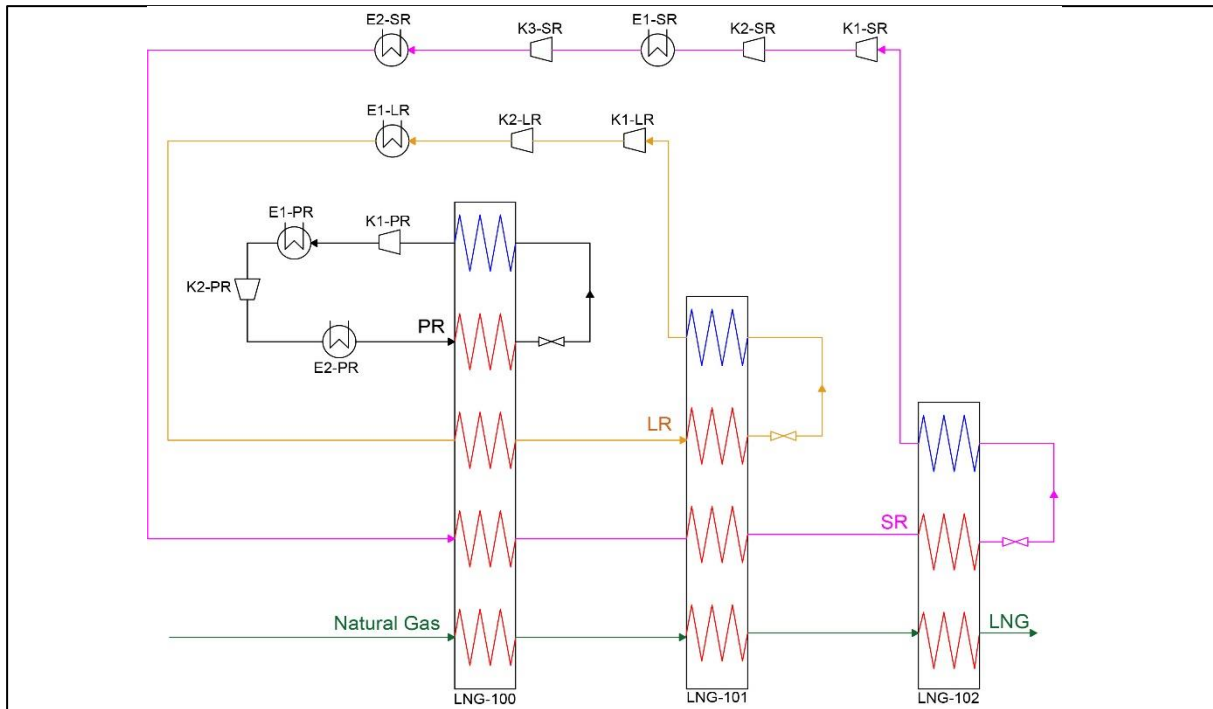

Figure 2 – MFC process flowsheet

3.2. Processes Modelling

The processes are modelled in Aspen Hysys v10 using the Peng-Robinson fluid package and have the following baseline specifications:

- The natural gas feed composition can be seen below (Table 1). As an assumption, the natural gas has been pre-treated and enters the process at 25°C, 50bar and 570780 kg/h (19.023kmol/s). The plant capacity is 4.5MTPA considering an operating factor of 90%.

Component	Methane	Ethane	Ethylene	Propane	Nitrogen
Mol Fraction	0.8905	0.1039	-	0.0002	0.0054

Table 1 – Natural gas feed composition

- The base-case refrigerant compositions for both processes are shown in Table 4 and Table 8. The compositions of all refrigerants are considered as a variable during the optimization

Component	<i>Mol Fraction</i>				
	Methane	Ethylene	Propane	n-Butane	Nitrogen
MR	0.3216	0.3506	0.1317	-	0.1961
PR	-	0.0726	0.7743	0.1531	-
LR	0.1055	0.7829	0.1116	-	-
SR	0.6928	0.2109	-	-	0.0962

Table 2 – Refrigerant compositions for base-case flowsheets

- For safety, the vapour temperature entering a compressor should not exceed 30°C; otherwise, a cooler need to be installed before the compressor (Wang, Zhang and Xu 2012). The compressor pressure ratios should be between 1.5 to 4 (Wang, Khalilpour and Abbas 2014).
- The pressure drop in LNG heat exchangers is zero for hot and cold streams but 30kPa in each water cooler or propane shell & tube heat exchanger (Ding et al. 2017).
- The LNG product should exit at a temperature of -160°C.

3.3. Economic Modelling

3.3.1 Equipment Costs Estimation:

These costs are related to the purchase of the equipment. Although general correlations given in (Towler and Sinnott 2013) can be used for cost estimation of compressors and coolers, the cost of the “cold box” (all the heat exchangers used for cooling down the natural gas and the refrigerants) is estimated based on the work done by (Wang, Khalilpour and Abbas 2014). The details are shown below:

- The purchase cost of centrifugal compressors is shown in equation (1), where C_{comp} is the price in USD in January 2010, S_{comp} is the driver power in kW and has its limits between 75kW and 30000kW (Towler and Sinnott 2013). If the driver power exceeds the upper limit established in the correlation, this power is divided and cost as more than one compressor would be being used.

$$C_{\text{comp}} = 580000 + 20000S_{\text{comp}}^{0.6} \quad (1)$$

- The purchase cost of coolers is shown in the equation (2), where C_{cooler} is the value in USD in January 2010, S_{cooler} is the cooler area in m^2 and has its limits between 10m^2 and 1000m^2 (Towler and Sinnott 2013). An overall heat transfer coefficient U of $500\text{W}/\text{m}^2 \cdot \text{K}$ is used for determining the transfer area in coolers that is a reasonable value for water and condensing hydrocarbons (Rohsenow, Hartnett and Cho 1998). If the area exceeds the upper limit established in the correlation, this area is divided and cost as more than one cooler would be being used.

$$C_{\text{cooler}} = 32000 + 70S_{\text{cooler}}^{1.2} \quad (2)$$

- For the cold box, the patent done by (Jager and Kaart 2009) states that an effective area of $73\text{MW}/\text{K}$ can liquefy $17.5\text{kmol}/\text{s}$ (8.73MTPA of LNG using the same composition as the natural gas feed and an operating factor of 90%). The total LNG plant cost is 1050USD per ton of LNG and 30% of that cost corresponds to installed equipment investment according to The Oxford Institute for Energy Studies (Songhurst 2018), and 34.85% of the equipment investment is destined to the “cold box” as (Yin et al. 2008) suggested in his work. Therefore, the cost for each $\text{MW}/^\circ\text{C}$ of the effective area can be estimated as:

$$\text{Cost of } 8.73\text{MTPA LNG Plant} = 1050 \frac{\text{USD}}{\text{TPA}} \times 8.73\text{MTPA} = 9166.5\text{MUSD}$$

$$\text{Cost of all Equipment} = 9166.5\text{MUSD} \times 30\% = 2749.95\text{MUSD}$$

$$\text{Cold Box Cost} = 2749.95\text{MUSD} \times 34.85\% = 958.36\text{MUSD}$$

$$\alpha = \frac{958.36\text{MUSD}}{73\text{MW}/^\circ\text{C}} = 13.13 \frac{\text{MUSD}}{\text{MW}/^\circ\text{C}}$$

Where α is the cost of each $\text{MW}/^\circ\text{C}$ of the effective area in millions of dollars in 2017, one year before (Songhurst 2018) published his work.

3.3.2. CAPEX

The total capital expenditure or CAPEX, considering the installation factors equal to 2.5 for compressors and 3.5 for coolers (Towler and Sinnott 2013) and updating these values using the Chemical Engineering Plant Cost Index (CEPCI), which was 550.8 for the year 2010 and 567.5 for the year 2017, yields:

$$\text{CAPEX} = \left(2.5 \sum_{i=1}^N C_{\text{comp}} + 3.5 \sum_{i=1}^M C_{\text{cooler}} \right) \frac{\text{CEPCI}_{2017}}{\text{CEPCI}_{2010}} + \alpha(\text{UA}_t) \quad (3)$$

Where UA_t is the total effective area of the “cold box” in $\text{MW}/^\circ\text{C}$, only compressors and coolers costs are updated because they are in 2010-year-basis.

3.3.3. OPEX

The operating expenditure or OPEX include raw material cost, electricity cost and cooling water cost and is equal to:

$$\text{OPEX} = \left(p_{\text{NG}} F_{\text{NG}} \text{HHV} + p_{\text{el}} \sum W_{\text{comp}} + p_{\text{cw}} \sum Q_{\text{cw}} \right) \text{HPA} \quad (4)$$

Where p_{NG} , p_{el} and p_{cw} are prices of natural gas, electricity and cooling water respectively which are equal to 2USD/MBTU, 10.99USD/GJ and 0.40USD/GJ (Wang, Khalilpour and Abbas 2014). F_{NG} is the natural gas flowrate (570780kg/h), HHV is the gross heating value of the natural gas (54036.18kJ/kg), W_{comp} is the work required by the compressors, Q_{cw} is the cooling duty in the coolers and HPA means the hours per annum (7884h/year).

Due to the natural gas flowrate does not change, the cost for raw material is:

$$p_{\text{NG}} F_{\text{NG}} (\text{HHV}) \text{HPA} = 2 \frac{\text{USD}}{\text{MBTU}} \times 570780 \frac{\text{kg}}{\text{h}} \times 54036.18 \frac{\text{kJ}}{\text{kg}} \times 7884 \frac{\text{h}}{\text{year}} \times \frac{\mathbf{1\text{MBTU}}}{\mathbf{1055055\text{kJ}}}$$

$$p_{\text{NG}} F_{\text{NG}} (\text{HHV}) \text{HPA} = 460.95 \times 10^6 \frac{\text{USD}}{\text{year}} = 460.95 \frac{\text{MUSD}}{\text{year}}$$

Note that Aspen Hysys calculated the gross heating value, the fraction in bold is a conversion factor, and the OPEX is calculated in millions of dollars per year. Therefore, equation (4) can be simplified to:

$$\text{OPEX} = 460.95 + \left(p_{\text{el}} \sum W_{\text{comp}} + p_{\text{cw}} \sum Q_{\text{cw}} \right) \text{HPA} \quad (5)$$

3.3.4. Total Annualized Cost

If no loan was made for the total capital investment, the total annualized cost or TAC only considers the operating cost and the depreciation of the capital investment for 10 years (Wang, Khalilpour and Abbas 2014), resulting in:

$$\text{TAC} = \frac{\text{CAPEX}}{10} + \text{OPEX} \quad (6)$$

CHAPTER 4

OPTIMIZATION

4.1. Method

In this work, genetic algorithm method was used to optimize the two process flowsheets for each objective function. The Genetic Algorithm can solve high non-linear optimization problems, such as the design of an LNG plant, mimicking biological evolution. It creates randomly an initial population between given bounds where the best individuals lead the next generation, approaching the solution with each generation. The genetic algorithm also prevents the local optimal solutions using crossover and mutation parameters and has the potential to find the global optimum. Genetic Algorithm was the most non-deterministic algorithm used according to (Austbø, Løvseth and Gundersen 2014) for LNG plant simulation and optimization studies.

This algorithm is carried out in MATLABTM because it is an excellent software for solving problems employing genetic algorithm and has a friendly interface where users can adjust parameters easily. The tuning parameters selected during the optimization of the MFC and C3MR are shown in Table 3. The optimization of the MFC is performed loop by loop, from the subcooling to the precooling, and only requires five variables (two compositions, two-level pressures and the molar flowrate), so MATLABTM recommends a population of 50. On the other hand, the optimization of the C3MR need seven variables (three compositions, two pressure levels, one intermediate temperature and the flowrate), so its initial population should be larger.

Parameters	MFC process	C3MR process
Population	50	100
Mutation	Adaptive feasible	Adaptive feasible
Crossover Function	Scatter	Scatter
Fraction of Migration	0.2	0.2
Population	100	100

Table 3 – Tuning parameters for genetic algorithm

A macro function in VBA is created to establish a communication between MATLAB™ and Aspen Hysys, and that macro uses as inputs the variables which will be optimized and returns a matrix where the parameters used in the optimization such as compressor work, cooling duty or effective area can be read by MATLAB™. This function is illustrated in Figure 3, and the VBA codes are shown in Appendix 1 to 4.

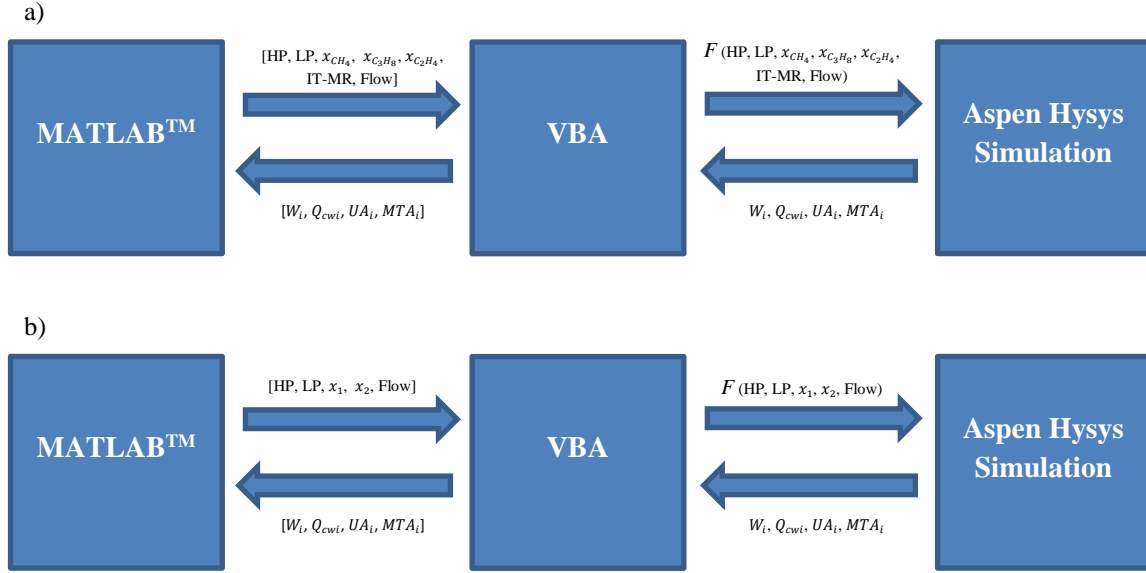

Figure 3 – Communication scheme for optimization of C3MR (a) and MFC (b) processes

4.2. Constraints

For both processes, the major constraints that all individual must satisfy are:

- The sum of component molar fractions for each refrigerant must be 1.

$$\text{PR: } x_{\text{C}_2\text{H}_4} + x_{\text{C}_3\text{H}_8} + x_{\text{C}_4\text{H}_{10}} = 1 \quad (7)$$

$$\text{LR: } x_{\text{CH}_4} + x_{\text{C}_2\text{H}_4} + x_{\text{C}_3\text{H}_8} = 1 \quad (8)$$

$$\text{SR: } x_{\text{N}_2} + x_{\text{CH}_4} + x_{\text{C}_2\text{H}_4} = 1 \quad (9)$$

$$\text{MR: } x_{\text{N}_2} + x_{\text{CH}_4} + x_{\text{C}_2\text{H}_4} + x_{\text{C}_3\text{H}_8} = 1 \quad (10)$$

- The minimum temperature approach in each LNG heat exchanger must be larger than 3°C.

$$\forall i \in \{100,101,102\}, \quad \Delta T_{\min}^{\text{LNG}-i} > 3 \quad (11)$$

- The vapour fraction in the inlet of each compression stage must be 1; this occurs when

the stream temperature is higher than the dew temperature at that given pressure.

$$\forall i \in \{K1 - PR, K1 - LR, K1 - SR, K1 - MR\}, T_i > T_i^{\text{dew}} \quad (12)$$

4.3. Optimization Objectives

The present work evaluates three objective functions: The total Capital Expenditure or CAPEX, the total Operating Expenditure or OPEX (which is equivalent to an indirect compression work optimization) and the Total Annualized Cost:

$$OF_1 = \min(\text{CAPEX}) \quad (13)$$

$$OF_2 = \min(\text{OPEX}) \quad (14)$$

$$OF_3 = \min(\text{TAC}) \quad (15)$$

CHAPTER 5

RESULTS AND DISCUSSION

5.1. C3MR Process

The best individuals for each objective function are shown in Table 4. The precooling propane requirement decreases when the highest MR pressure increases because the heat capacity of the MR increases with the pressure and this benefits the heat transfer, reducing the amount of propane that flow through the precooling heat exchangers. Also, the MR pressure is more substantial when the objective function considers the effective area of the heat exchangers. The intermediate temperature between the LNG exchangers increases when minimising the effective area is more important than the compression work (OF₁ has the lowest intermediate temperature) because this helps to separate the composite curves in the LNG exchangers and therefore reduces their effective areas. Analysing the MR composition, the methane fraction is higher for the less effective area (OF₁), and the nitrogen fraction is higher for less compression work (OF₂), the other components remain almost the same for all cases.

	Units	Base Case	OF ₁	OF ₂	OF ₃
Precooling					
Flowrate	kmol/s	12.88	12.53	13.49	12.24
Propane	mol%	100%	100%	100%	100%
MR					
Highest Pressure	kPa	5100.00	5080.05	4070.42	5838.15
Lowest Pressure	kPa	200.00	200.00	463.22	385.38
Methane	mol%	32.16%	35.60%	32.60%	33.50%
Propane	mol%	13.17%	13.70%	13.40%	11.90%
Ethylene	mol%	35.06%	40.00%	39.60%	39.90%
Nitrogen	mol%	19.61%	10.70%	14.40%	14.70%
Flowrate	kmol/s	-83.69	-93.96	-116.85	-110.57
Int. Temperature	°C	19.00	16.06	18.85	16.70

Table 4 – Base Case and Best Individuals for each Objective Function, C3MR process

Compression works, cooling duties and effective areas are shown in Table 5. The OF₁ has the most considerable total compression work and total cooling duty and the lowest effective area

because reducing the LNG exchanger costs has a higher impact on the capital investment than the compressors or coolers. Minimising the TAC (OF₃) produces a saving in compressor work respect to OF₁ at the expense of a significant increment in the effective area of LNG-100 and as a result, the TAC of OF₁ and OF₃ are very close to each other, being OF₃ only 3MUSD/year less than OF₁. The effective area of LNG-100 in OF₂ is dramatically more extensive than in the other cases because the temperature approach in that exchanger is only 4.49°C, much less than in the other cases.

Compressor Works		Base Case	OF ₁	OF ₂	OF ₃
K1-MR	kW	59,172.77	48,843.04	57,233.92	50,756.81
K2-MR	kW	77,741.78	63,738.47	74,556.34	66,479.06
K3-MR	kW	71,043.72	58,810.41	642.19	27,844.60
K1-C3	kW	10,492.64	9,918.88	11,680.71	9,741.41
K2-C3	kW	18,517.91	17,680.44	19,849.47	17,388.48
K3-C3	kW	32,988.45	32,052.83	34,637.00	31,328.63
Total	kW	269,957.27	231,044.06	198,599.63	203,538.99
Cooler Duties		Base Case	OF ₁	OF ₂	OF ₃
E1-MR	kW	90,915.87	70,783.97	101,766.23	85,008.04
E2-MR	kW	93,806.23	81,147.93	805.34	44,127.48
E1-C3	kW	214,856.61	208,733.61	225,649.51	204,024.91
Total	kW	399,578.71	360,665.51	328,221.08	333,160.43
LNG Effective Area		Base Case	OF ₁	OF ₂	OF ₃
Precooling	kW/°C	14,839.24	14,447.25	15,519.34	14,121.24
LNG-100	kW/°C	7,256.92	7,226.39	24,697.98	13,380.25
LNG-101	kW/°C	4,875.91	4,541.65	5,368.97	5,037.20
Total	kW/°C	12,132.83	11,768.04	30,066.95	18,417.45

Table 5 – Optimization Results for C3MR process

Equipment purchase costs are shown in Table 6. The most expensive equipment is the LNG exchanger, followed by the compressors and coolers respectively. An important saving in compressor cost is obtained for OF₂ because the low power requirement respect to the other cases, however, this produces a considerable increment in LNG exchangers and therefore the highest CAPEX of all cases. Also, the precooling section has the largest effective area requirement and therefore is the most expensive part of the cold box.

Compressor Cost		Base Case	OF ₁	OF ₂	OF ₃
K1-MR	MUSD	20.42	18.33	20.04	18.73
K2-MR	MUSD	28.43	25.43	27.76	26.03
K3-MR	MUSD	27.02	20.35	0.00	9.87
K1-C3	MUSD	5.75	5.58	6.09	5.53
K2-C3	MUSD	7.85	7.65	8.16	7.58
K3-C3	MUSD	14.73	14.49	15.13	14.31
Total	MUSD	104.20	91.83	77.19	82.05
Cooler Cost		Base Case	OF ₁	OF ₂	OF ₃
E1-MR	MUSD	1.40	1.17	1.54	1.30
E2-MR	MUSD	1.53	1.33	0.07	1.08
E1-C3	MUSD	7.08	6.90	7.36	6.75
Total	MUSD	10.00	9.41	8.98	9.13
LNG Cost		Base Case	OF ₁	OF ₂	OF ₃
Precooling	MUSD	194.81	189.67	203.74	185.39
LNG-100	MUSD	95.27	94.87	324.24	175.66
LNG-101	MUSD	64.01	59.62	70.48	66.13
Total	MUSD	354.09	344.16	598.46	427.17

Table 6 – Equipment Purchase Cost for C3MR process

The economic results are shown in Table 7. Reducing the compression work produces an increment in the heat exchanger effective area and this inverse relation can be clearly seen in Table 7, where OF₂ is 215MUSD more expensive than OF₁ and this increment is not fully compensated by saving electricity in the compressors. Although OF₃ has the lowest TAC, OF₁ is only 3MUSD/year more expensive than OF₃ because of the saving in LNG exchangers.

The optimal operating conditions in a C3MR liquefaction plant could be either OF₁ or OF₃ if the total annualized cost is the most critical factor to be considered, and this decision should be taken analysing other aspects such as safety (OF₃ work at almost 6000kPa) or a potential increment in plant capacity (both have this potential because of their low effective area).

		Base Case	OF ₁	OF ₂	OF ₃
Compressors	MUSD	268.39	236.54	198.82	211.34
Coolers	MUSD	36.07	33.93	32.38	32.92
LNG Exch.	MUSD	354.09	344.16	598.46	427.17
CAPEX	MUSD	658.56	614.63	829.67	671.43
Raw Material	MUSD/y	460.95	460.95	460.95	460.95
Electricity	MUSD/y	84.21	72.07	61.95	63.49
Cooling Water	MUSD/y	4.54	4.09	3.73	3.78
OPEX	MUSD/y	549.69	537.11	526.62	528.22
TAC	MUSD/y	615.55	598.58	609.59	595.36

Table 7 – Economic Results for C3MR process

5.2. MFC Process

The best individuals of MFC process are shown in Table 8. The precooling flowrates tend to increase when minimising the effective area is the priority (OF₁ has the largest precooling flowrate), pressure levels are very similar in all cases, but the propane molar fraction is much larger for OF₁ and OF₂. This indicates that the precooling loop approaches a pure propane precooling when the effective area should be minimised.

Liquefaction and subcooling flowrates are similar; however, the pressure levels for OF₃ are much higher as was observed for the C3MR process as well. The ethylene fraction in LR is favoured when optimizing the effective area while the compositions in SR have roughly the same values. Also, these refrigerants show similar behaviour as MR, larger pressures when UA is the more influential factor in the optimization, lower pressures when the compression work is the objective and an intermediate state for optimizing the TAC.

			Base Case	OF ₁	OF ₂	OF ₃
Precooling	Flowrate	kmol/s	15.00	14.79	12.22	13.54
	Highest Pressure	kPa	1700.00	1284.00	1273.27	1274.27
	Lowest Pressure	kPa	150.00	102.00	174.55	105.182
	Ethylene	mol%	7.26	5.73	6.90	5.20
	Propane	mol%	77.43	85.00	73.60	83.50
	n-Butane	mol%	15.31	9.27	19.50	11.30

Liquefaction	Flowrate	kmol/s	10.00	10.30	9.41	10.66
	Highest Pressure	kPa	2300.00	2011.03	1853.42	2031.09
	Lowest Pressure	kPa	170.00	150.57	403.29	321.92
	Methane	mol%	10.55	6.10	6.20	5.80
	Ethylene	mol%	78.29	81.40	75.20	83.90
	Propane	mol%	11.16	12.5	18.60	10.30
Subcooling	Flowrate	kmol/s	11.80	12.21	12.71	12.21
	Highest Pressure	kPa	5200.00	4864.47	4120.26	4950.01
	Lowest Pressure	kPa	180.00	220.10	308.92	293.70
	Nitrogen	mol%	9.62	12.8	11.40	11.40
	Methane	mol%	69.28	60.10	61.00	60.10
	Ethylene	mol%	21.09	27.10	27.60	28.50

Table 8 – Base Case and Best Individuals for each Objective Function, MFC process

Optimization results of MFC are shown in Table 9. There is a significant decrement in power consumption and cooler duty in OF₂ and OF₃ respect to the base case while the effective area is slightly larger in OF₃ but dramatically larger in OF₂ because of the small distance between composite curves in OF₂. The equipment purchase cost is shown in Table 10 and can be seen as a saving in compressor cost at the expense of a considerable increment in LNG costs for OF₂. As it was observed for the C3MR, the precooling exchanger is much more expensive than the other LNG exchangers due to the larger effective area needed in this section. It is important to mention that the MFC base case does not require the cooler E1-SR because the inlet temperature of K3-SR is less than 30°C.

Compressor Works		Base Case	OF ₁	OF ₂	OF ₃
K1-PR	kW	59,743.76	65,260.81	57,149.58	63,626.43
K2-PR	kW	50,146.74	58,865.22	23,332.28	51,729.87
K1-LR	kW	35,667.92	33,698.46	31,811.56	35,055.40
K2-LR	kW	48,961.29	45,948.01	7,252.84	19,157.05
K1-SR	kW	18,494.07	30,437.70	20,181.99	27,899.65
K2-SR	kW	24,706.13	42,346.99	26,878.47	38,909.84
K3-SR	kW	91,219.77	39,499.53	55,457.73	26,259.58
Total	kW	328,939.67	316,056.72	222,064.45	262,637.82

Cooler Duties		Base Case	OF ₁	OF ₂	OF ₃
E1-PR	kW	13,872.48	38,525.46	59,769.20	57,121.61
E2-PR	kW	282,727.12	287,334.38	213,931.89	263,859.12
E1-LR	kW	62,203.50	47,202.80	13,875.39	23,109.93
E1-SR	kW	0.00	25,243.77	522.66	15,401.49
E2-SR	kW	99,743.39	47,357.11	63,571.86	32,752.49
Total	kW	458,546.48	445,663.53	351,671.00	392,244.64
LNG Effective Area		Base Case	OF ₁	OF ₂	OF ₃
LNG-100	kW/°C	19,331.37	12,627.99	38,628.64	15,029.75
LNG-101	kW/°C	4,721.19	4,423.49	21,026.07	8,042.56
LNG-102	kW/°C	6,249.50	6,806.17	11,027.52	9,546.54
Total	kW/°C	30,302.06	23,857.65	70,682.23	32,618.85

Table 9 – Optimization Results for MFC process

The more expensive compressors and coolers are found in the precooling loop (Table 10) because this loop has to cool down the natural gas and the other refrigerants at the same time.

Compressor Cost		Base Case	OF ₁	OF ₂	OF ₃
K1-PR	MUSD	20.53	25.77	20.02	25.40
K2-PR	MUSD	18.60	20.36	8.93	18.93
K1-LR	MUSD	15.38	14.90	14.43	15.23
K2-LR	MUSD	18.35	17.71	4.72	8.00
K1-SR	MUSD	7.85	14.09	8.24	9.88
K2-SR	MUSD	9.22	16.92	9.67	16.14
K3-SR	MUSD	35.27	16.27	19.69	9.55
Total	MUSD	125.21	126.02	85.71	103.13
Cooler Cost		Base Case	OF ₁	OF ₂	OF ₃
E1-PR	MUSD	0.65	1.15	1.30	1.32
E2-PR	MUSD	6.39	6.19	6.51	5.82
E1-LR	MUSD	0.90	0.82	0.45	0.62
E1-SR	MUSD	0.00	0.59	0.06	0.47
E2-SR	MUSD	1.00	0.78	0.90	0.68
Total	MUSD	8.93	9.53	9.22	8.90

LNG Cost		Base Case	OF ₁	OF ₂	OF ₃
LNG-100	MUSD	253.79	165.78	507.12	197.31
LNG-101	MUSD	61.98	58.07	276.03	105.58
LNG-102	MUSD	82.04	89.35	144.77	125.33
Total	MUSD	397.81	313.21	927.93	428.23

Table 10 – Equipment Purchase Cost for MFC process

The economic results are shown in Table 11 and the behaviour is similar to the observed for C3MR process. OF₁ has the lowest CAPEX but the highest OPEX because of the inverse relation between effective area and compressor work. On the other hand, OF₂ has the highest CAPEX but the lowest OPEX while OF₃ has intermediate values for CAPEX and OPEX that yields in the lowest TAC.

		Base Case	OF ₁	OF ₂	OF ₃
Compressors	MUSD	322.51	324.60	220.77	265.63
Coolers	MUSD	32.21	34.36	33.24	32.10
LNG Exch.	MUSD	397.81	313.21	927.93	428.23
CAPEX	MUSD	752.54	672.17	1,181.94	725.95
Raw Material	MUSD/y	460.95	460.95	460.95	460.95
Electricity	MUSD/y	102.60	98.59	69.27	81.92
Cooling Water	MUSD/y	5.21	5.06	3.99	4.45
OPEX	MUSD/y	568.76	564.59	534.21	547.33
TAC	MUSD/y	644.01	631.81	652.40	619.92

Table 11 – Economic Results for MFC process

5.3. Processes Comparison

An illustrative comparison between C3MR and MFC processes is shown in Figure 4. The C3MR process has better objectives values than the MFC process (CAPEX, OPEX and TAC). However, these are relatively close to each other, considering the error of the economic estimation ($\pm 30\%$). The best C3MR CAPEX is 57.54MUSD (9.36%) less than the best MFC CAPEX, the best C3MR OPEX is 7.59MUSD/y (1.44%) less than the best MFC OPEX, and the best C3MR TAC is 24.56MUSD/y (4.12%) less than the best MFC TAC. These results

indicate that MFC process can be a good substitute of C3MR process for new plants if, for example, the effective area or the compressor cost decreases. Another important fact is that MFC reports a little larger compression works and therefore slightly significant electricity costs in the best OPEX cases but much larger effective areas than C3MR in the same situations.



Figure 4 – C3MR and MFC Objective Functions Comparison

The composite curve plots for all the scenarios are shown in Figure 5 and Figure 6. The minimum temperature approach is reached with OF2, minimising the OPEX function, obtaining values as short as 3°C for the precooling section in the MFC and slightly larger for liquefaction and subcooling. These values explain the less compression work required for OF2 (shorter minimum temperature approach) at the expense of higher heat exchanger areas (capital cost of LNG exchanger is much more expensive in these scenarios). Optimizing the CAPEX results in more extensive temperature approaches at the expense of more compression work while the TAC results report average temperature approaches and compression work requirements.

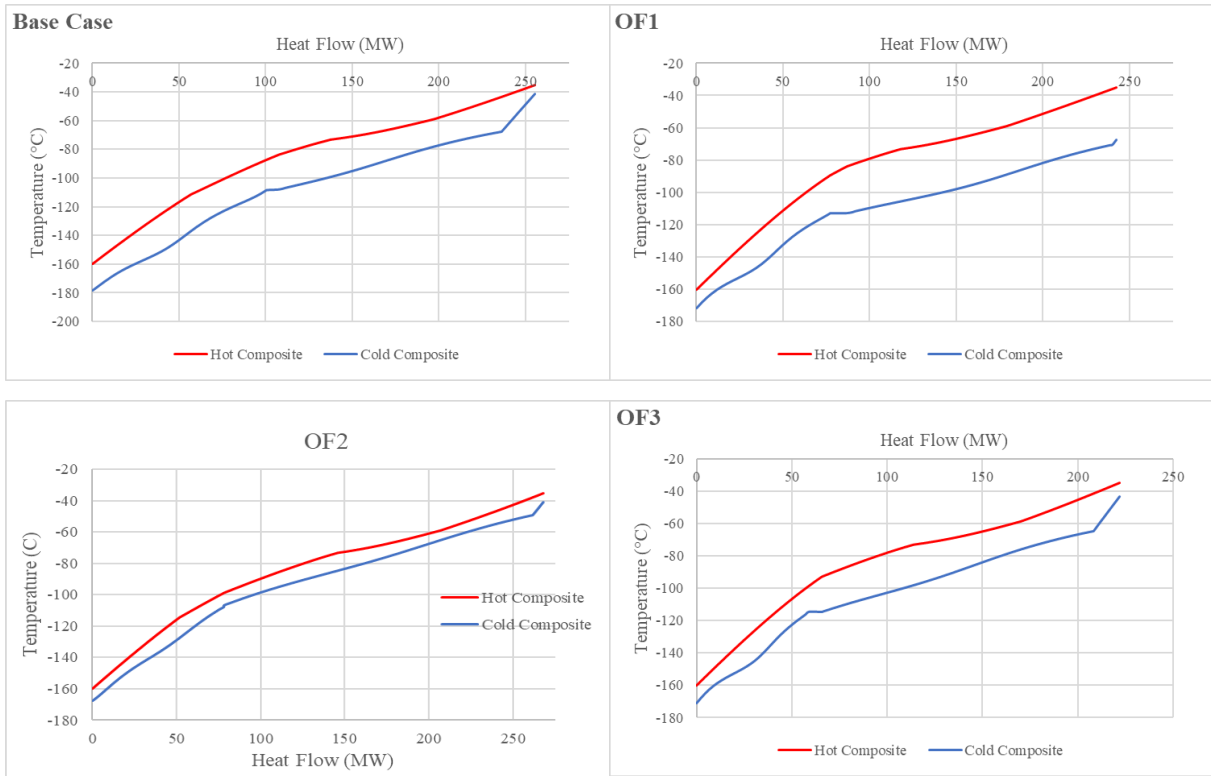

Figure 5 – C3MR Composite Curves

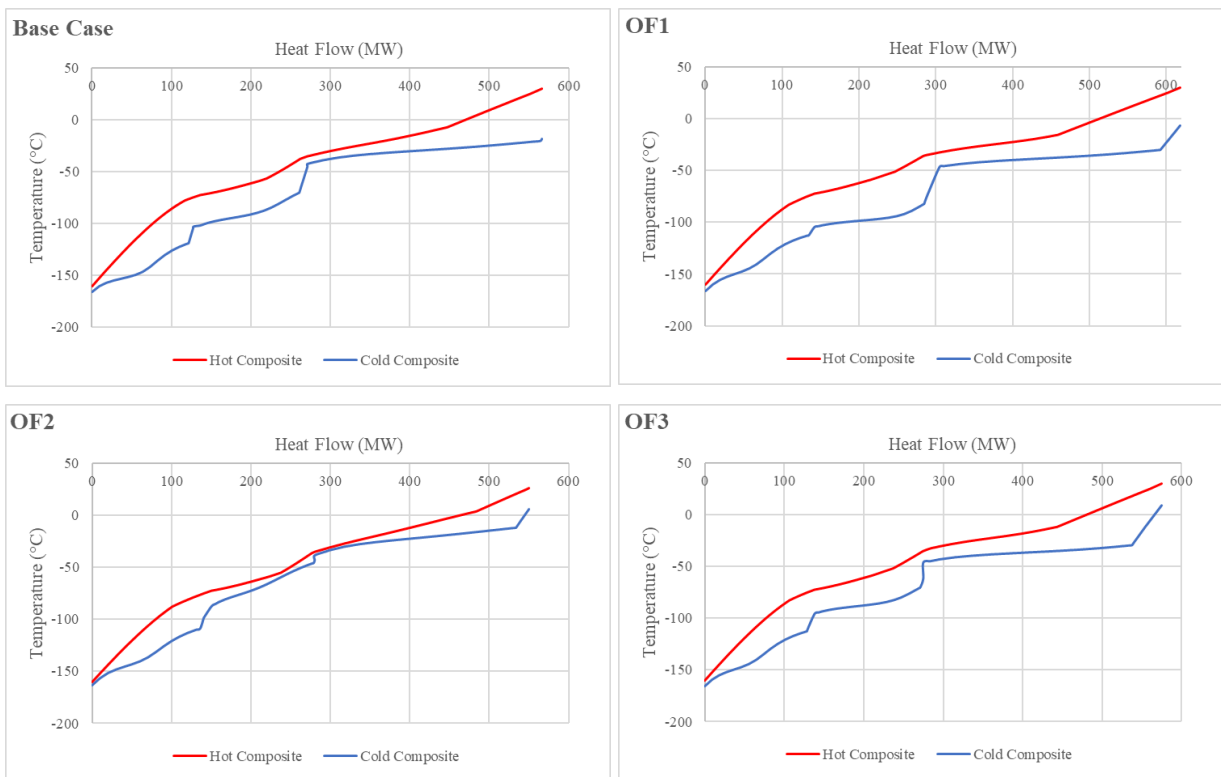

Figure 6 – MFC Composite Curves

CHAPTER 6

CONCLUSIONS AND RECOMMENDATIONS

The present study optimized and compared the C3MR and the MFC processes analysing economic objectives using costing functions available in the open literature for general equipment and estimating a cost for each MW/K for LNG heat exchangers (cold box). The genetic algorithm was employed for optimizing these high non-linear LNG processes. The CAPEX (OF_1) and TAC (OF_3) best scenarios are obtained at high pressures, low refrigerant flowrates for C3MR and high refrigerant flowrates for MFC, and high ethylene molar fraction in the refrigerants for both processes while the OPEX reports the opposite behaviour.

In all the scenarios, the essential equipment exceeded the upper bond established for costing and therefore, they were divided into small pieces of equipment to perform the cost evaluation. These results are in concordance with what (Yin et al. 2008) suggested, where the cold box and the compressors are the equipment which increases the most the capital investment of an LNG plant.

The costing of the cold box was performed using many assumptions such as LNG plant breakdown proposed by (Yin et al. 2008) and the patent by (Jager and Kaart 2009). This patent only considered an MCHX for liquefaction and subcooling and not for precooling, therefore for a better estimation of the precooling cost, other methods such as the differential method for sizing plate fin heat exchanger could be employed.

Although the optimization of C3MR process produced lower values respect to the MFC for the all objective functions, MFC results are relatively close within the error as was mentioned in section 5.3. This means that the MFC should be considered if a new LNG plant to liquefy natural gas similar to the feed used was constructed. More accurate methods for estimating the costs of compressors, coolers and LNG exchangers could predict better scenarios for MFC. However, the C3MR is recommended for a new LNG plant based on the results of the present report.

The best-operating conditions should be those that make the TAC as low as possible because this state represents a balance between operating and capital expenditure. If the payback period

were more than ten years, the capital cost would become less critical and the OPEX would be the objective function that should be more considered.

The optimization of the MFC was carried out loop by loop as (Ding et al. 2017) recommended from the subcooling loop to the precooling loop taking five variables in each loop. For the C3MR, only the mixed refrigerant cycle was optimized using seven variables, so it is still possible to find better-operating conditions for the propane precooling cycle.

The genetic algorithm is a method that takes a considerable amount of time to converge depending on the number of variables used. After this optimization, a gradient algorithm for optimizing the processes can be employed to explore a bit more the vicinity of the solution obtained by the genetic algorithm. Also, a direct connection between MATLABTM and Aspen Hysys would reduce significantly the calculation time.

REFERENCES

- Austbø, Bjørn, Sigurd Weidemann Løvseth, and Truls Gundersen. 2014. "Annotated Bibliography—Use of Optimization in Lng Process Design and Operation." *Computers & Chemical Engineering* 71: 391-414. <https://doi.org/https://doi.org/10.1016/j.compchemeng.2014.09.010>.
- BP. 2018. *Bp Statistical Review of World Energy*. <https://www.bp.com/content/dam/bp/business-sites/en/global/corporate/pdfs/energy-economics/statistical-review/bp-stats-review-2018-full-report.pdf>.
- Ding, He, Heng Sun, Shoujun Sun, and Cheng Chen. 2017. "Analysis and Optimisation of a Mixed Fluid Cascade (Mfc) Process." *Cryogenics* 83: 35-49. <https://doi.org/https://doi.org/10.1016/j.cryogenics.2017.02.002>.
- Eiksund, Oddmar, Eivind Brodal, and Steven Jackson. 2018. "Optimization of Pure-Component Lng Cascade Processes with Heat Integration." *Energies* 11 (1): 202. <https://doi.org/10.3390/en11010202>.
- Fahmy, M. F. M., H. I. Nabih, and M. El-Nigeily. 2016. "Enhancement of the Efficiency of the Open Cycle Phillips Optimized Cascade Lng Process." *Energy Conversion and Management* 112: 308-318. <https://doi.org/https://doi.org/10.1016/j.enconman.2016.01.022>.
- Hatcher, Prue, Rajab Khalilpour, and Ali Abbas. 2012. "Optimisation of Lng Mixed-Refrigerant Processes Considering Operation and Design Objectives." *Computers & Chemical Engineering* 41: 123-133. <https://doi.org/https://doi.org/10.1016/j.compchemeng.2012.03.005>.
- Jager, Marco Dick, and Sander Kaart. 2009. Method and Apparatus for Cooling a Hydrocarbon Stream. United States filed and issued
- Jensen, Jørgen Bauck. 2008. 'Optimal Operation of Refrigeration Cycles.' edited by Fakultet for Naturvitenskap Og Teknologi Institutt for Kjemisk Prosessteknologi Norges Teknisk-Naturvitenskapelige Universitet: Fakultet for naturvitenskap og teknologi.
- Jensen, Jørgen Bauck, and Sigurd Skogestad. 2006. "Optimal Operation of a Simple Lng Process." *IFAC Proceedings Volumes* 39 (2): 241-246. <https://doi.org/https://doi.org/10.3182/20060402-4-BR-2902.00241>.
- Kidnay, Arthur J., William R. Parrish, and Daniel G. McCartney. 2011. *Fundamentals of Natural Gas Processing, Second Edition*. 2 ed.
- Lee, Inkyu, and Il Moon. 2016. "Total Cost Optimization of a Single Mixed Refrigerant Process Based on Equipment Cost and Life Expectancy." *Industrial & Engineering Chemistry Research* 55 (39): 10336-10343. <https://doi.org/10.1021/acs.iecr.6b01864>.
- Lee, Inkyu, and Il Moon. 2017. "Economic Optimization of Dual Mixed Refrigerant Liquefied Natural Gas Plant Considering Natural Gas Extraction Rate." *Industrial & Engineering Chemistry Research* 56 (10): 2804-2814. <https://doi.org/10.1021/acs.iecr.6b04124>.
- Lee, Inkyu, Jinwoo Park, and Il Moon. 2018. "Key Issues and Challenges on the Liquefied Natural Gas Value Chain: A Review from the Process Systems Engineering Point of View." *Industrial & Engineering Chemistry Research* 57 (17): 5805-5818. <https://doi.org/10.1021/acs.iecr.7b03899>.
- Pereira, Clementino, and Domingos Lequisiga. 2014. "Technical Evaluation of C3-Mr and Cascade Cycle on Natural Gas Liquefaction Process." *International Journal of Chemical Engineering and Applications* 5 (6): 451-456. <https://doi.org/10.7763/IJCEA.2014.V5.427>.
- Qyyum, Muhammad Abdul, Kinza Qadeer, and Moonyong Lee. 2018. "Comprehensive Review of the Design Optimization of Natural Gas Liquefaction Processes: Current Status and Perspectives." *Industrial & Engineering Chemistry Research* 57 (17): 5819-5844. <https://doi.org/10.1021/acs.iecr.7b03630>.
- Sanavandi, Hamid, and Masoud Ziabasharhagh. 2016. "Design and Comprehensive Optimization of C3mr Liquefaction Natural Gas Cycle by Considering Operational Constraints." *Journal of Natural Gas Science and Engineering* 29: 176-187. <https://doi.org/https://doi.org/10.1016/j.jngse.2015.12.055>.
- Songhurst, Brian. 2018. *Lng Plant Cost Reduction 2014-18*. <https://www.oxfordenergy.org/wpcms/wp-content/uploads/2018/10/LNG-Plant-Cost-Reduction-2014%E2%80%9318-NG137.pdf>.
- Taleshbahrami, Hamidreza, and Hamid Saffari. 2010. "Optimization of the C3mr Cycle with Genetic Algorithm." *Transactions of the Canadian Society for Mechanical Engineering* 34: 433-448.

- Towler, Gavin, and Ray Sinnott. 2013. "Chapter 7 - Capital Cost Estimating." In *Chemical Engineering Design (Second Edition)*, Gavin Towler and Ray Sinnott, eds., 307-354. Boston: Butterworth-Heinemann. <https://doi.org/https://doi.org/10.1016/B978-0-08-096659-5.00007-9>.
- Usama, M. N., A. Sherine, and M. Shuhaimi. 2011. "Technology Review of Natural Gas Liquefaction Processes." *Journal of Applied Sciences* 11 (21): 3541-3546. <https://doi.org/10.3923/jas.2011.3541.3546>.
- Wahl, Per Eilif, Sigurd Weidemann Løvseth, and Mona Jacobsen Mølnevik. 2013. "Optimization of a Simple Lng Process Using Sequential Quadratic Programming." *Computers & Chemical Engineering* 56: 27-36. <https://doi.org/https://doi.org/10.1016/j.compchemeng.2013.05.001>.
- Wang, Meiqian, Jian Zhang, and Qiang Xu. 2012. "Optimal Design and Operation of a C3mr Refrigeration System for Natural Gas Liquefaction." *Computers & Chemical Engineering* 39: 84-95. <https://doi.org/https://doi.org/10.1016/j.compchemeng.2011.12.003>.
- Wang, Mengyu, Rajab Khalilpour, and Ali Abbas. 2014. "Thermodynamic and Economic Optimization of Lng Mixed Refrigerant Processes." *Energy Conversion and Management* 88: 947-961. <https://doi.org/10.1016/j.enconman.2014.09.007>.
- Yin, Q. S., H. Y. Li, Q. H. Fan, and L. X. Jia. 2008. "Economic Analysis of Mixed-Refrigerant Cycle and Nitrogen Expander Cycle in Small Scale Natural Gas Liquefier." *AIP Conference Proceedings* 985 (1): 1159-1165. <https://doi.org/10.1063/1.2908467>.

APPENDICES

APPENDIX 1: VBA Macro for C3MR process

```
Public Function RESULTS(HP_MR As Double, LP_MR As Double, ch4 As Double, c3h8 As Double, c2h4  
As Double, IT_MR As Double, Flowrate_MR As Double) As Variant
```

```
Dim hyApp As HYSYS.Application  
Dim simCase As SimulationCase  
Dim pstream As ProcessStream  
Dim compositions(4) As Variant  
Dim Work1 As Object, Work2 As Object, Work3 As Object, Work4 As Object, Work5 As Object, Work6  
As Object  
Dim HeatCooler1 As Object, HeatCooler2 As Object, HeatCooler3 As Object  
Dim HX1 As Object, HX2 As Object, HX3 As Object, HX4 As Object, HX5 As Object, HX6 As Object  
Dim LNG1 As Object, LNG2 As Object  
Dim matrix(7, 4) As Variant
```

```
'LOADING HYSYS SIMULATION CASE
```

```
Set hyApp = CreateObject("HYSYS.Application")  
hyApp.Visible = True  
hyApp.SimulationCases.Open ("I:\C3MR simulation\MINCAPEX\C3MR_MR_MINCAPEXStudy.hsc")  
Set simCase = hyApp.ActiveDocument
```

```
compositions(0) = ch4  
compositions(1) = 0  
compositions(2) = c3h8  
compositions(3) = c2h4  
compositions(4) = 1 - ch4 - c3h8 - c2h4
```

```
'READ DATA FROM FUNCTION ARGUMENT TO "MR-1"
```

```
Set pstream = simCase.Flowsheet.MaterialStreams.Item("MR-1")  
pstream.ComponentMolarFraction.Values = compositions  
pstream.PressureValue = HP_MR  
pstream.MolarFlowValue = Flowrate_MR
```

```
Set pstream = simCase.Flowsheet.MaterialStreams.Item("NG-6")  
pstream.TemperatureValue = IT_MR
```

```
Set pstream = simCase.Flowsheet.MaterialStreams.Item("MR-V-5")  
pstream.PressureValue = LP_MR
```

```
'OBTAINING COMPRESSOR WORKS
```

```
Set Work1 = simCase.Flowsheet.Operations.Item("K1-MR")  
matrix(0, 0) = Work1.Energy.GetValue("kW")  
Set Work2 = simCase.Flowsheet.Operations.Item("K2-MR")  
matrix(1, 0) = Work2.Energy.GetValue("kW")  
Set Work3 = simCase.Flowsheet.Operations.Item("K3-MR")  
matrix(2, 0) = Work3.Energy.GetValue("kW")  
Set Work4 = simCase.Flowsheet.Operations.Item("K1-C3")  
matrix(3, 0) = Work4.Energy.GetValue("kW")  
Set Work5 = simCase.Flowsheet.Operations.Item("K2-C3")  
matrix(4, 0) = Work5.Energy.GetValue("kW")  
Set Work6 = simCase.Flowsheet.Operations.Item("K3-C3")  
matrix(5, 0) = Work6.Energy.GetValue("kW")
```

```
'OBTAINING COOLER DATA
```

```
Set HeatCooler1 = simCase.Flowsheet.Operations.Item("E1-MR")  
matrix(0, 1) = HeatCooler1.Duty.GetValue("kW")  
matrix(1, 1) = HeatCooler1.FeedTemperature.GetValue("C")  
matrix(2, 1) = HeatCooler1.ProductTemperature.GetValue("C")
```

```
Set HeatCooler2 = simCase.Flowsheet.Operations.Item("E2-MR")  
matrix(0, 2) = HeatCooler2.Duty.GetValue("kW")  
matrix(1, 2) = HeatCooler2.FeedTemperature.GetValue("C")  
matrix(2, 2) = HeatCooler2.ProductTemperature.GetValue("C")
```

```
Set HeatCooler3 = simCase.Flowsheet.Operations.Item("E1-C3")  
matrix(0, 3) = HeatCooler3.Duty.GetValue("kW")  
matrix(1, 3) = HeatCooler3.FeedTemperature.GetValue("C")  
matrix(2, 3) = HeatCooler3.ProductTemperature.GetValue("C")
```

```
'OBTAINING HX DATA
```

```
Set HX1 = simCase.Flowsheet.Operations.Item("HX1-C3")
```

```
matrix(0, 4) = HX1.UA.GetValue("kJ/C-s")
Set HX2 = simCase.Flowsheet.Operations.Item("HX2-C3")
matrix(1, 4) = HX2.UA.GetValue("kJ/C-s")
Set HX3 = simCase.Flowsheet.Operations.Item("HX3-C3")
matrix(2, 4) = HX3.UA.GetValue("kJ/C-s")
Set HX4 = simCase.Flowsheet.Operations.Item("HX4-C3")
matrix(3, 4) = HX4.UA.GetValue("kJ/C-s")
Set HX5 = simCase.Flowsheet.Operations.Item("HX5-C3")
matrix(4, 4) = HX5.UA.GetValue("kJ/C-s")
Set HX6 = simCase.Flowsheet.Operations.Item("HX6-C3")
matrix(5, 4) = HX6.UA.GetValue("kJ/C-s")
```

'OBTAINING LNG DATA

```
Set LNG1 = simCase.Flowsheet.Operations.Item("LNG-100")
matrix(6, 4) = LNG1.UA.GetValue("kJ/C-s")
matrix(4, 2) = LNG1.MinApproach.GetValue("C")
Set LNG2 = simCase.Flowsheet.Operations.Item("LNG-101")
matrix(7, 4) = LNG2.UA.GetValue("kJ/C-s")
matrix(4, 3) = LNG2.MinApproach.GetValue("C")
```

'VAPOUR FRACTION INLET FIRST COMPRESSOR

```
Set pstream = simCase.Flowsheet.MaterialStreams.Item("MR-8")
matrix(5, 3) = pstream.VapourFraction
```

```
RESULTS = matrix
```

```
End Function
```

APPENDIX 2: VBA Macro for MFC process – Subcooling Loop

```
Public Function RESULTS(HP_SR As Double, LP_SR As Double, Xch4_SR As Double, Xn2_SR As Double,
Flowrate_SR As Double) As Variant

Dim hyApp As HYSYS.Application
Dim simCase As SimulationCase
Dim pstream As ProcessStream
Dim Work1 As Object, Work2 As Object, Work3 As Object
Dim compositions(5) As Variant
Dim HeatCooler1 As Object, HeatCooler2 As Object
Dim LNG1 As Object
Dim matrix(2, 3) As Variant

'LOADING HYSYS SIMULATION CASE
Set hyApp = CreateObject("HYSYS.Application")
hyApp.Visible = True
hyApp.SimulationCases.Open ("I:\MFC simulation\MIN CAPEX\MFC_MINCAPEX_Final.hsc")
Set simCase = hyApp.ActiveDocument

'READ DATA FROM FUNCTION ARGUMENT TO SUBCOOLING LOOP

compositions(0) = Xch4_SR
compositions(1) = 0
compositions(2) = 0
compositions(3) = Xn2_SR
compositions(4) = 1 - Xch4_SR - Xn2_SR
compositions(5) = 0

'SUBCOOLING REFRIGERANT COMPOSITION AND FLOWRATE
Set pstream = simCase.Flowsheet.MaterialStreams.ITEM("SR-3")
pstream.ComponentMolarFraction.Values = compositions
pstream.MolarFlowValue = Flowrate_SR

'HIGH PRESSURE
Set pstream = simCase.Flowsheet.MaterialStreams.ITEM("SR-10")
pstream.PressureValue = HP_SR

'LOW PRESSURE
Set pstream = simCase.Flowsheet.MaterialStreams.ITEM("SR-5")
pstream.PressureValue = LP_SR

'SIMULATION RESULTS

'OBTAINING COMPRESSOR WORKS
Set Work1 = simCase.Flowsheet.Operations.ITEM("K1-SR")
matrix(0, 0) = Work1.Energy.GetValue("kW")
Set Work2 = simCase.Flowsheet.Operations.ITEM("K2-SR")
matrix(1, 0) = Work2.Energy.GetValue("kW")
Set Work3 = simCase.Flowsheet.Operations.ITEM("K3-SR")
matrix(2, 0) = Work3.Energy.GetValue("kW")

'OBTAINING COOLER DATA
Set HeatCooler1 = simCase.Flowsheet.Operations.ITEM("E1-SR")
matrix(0, 1) = HeatCooler1.Duty.GetValue("kW")
matrix(1, 1) = HeatCooler1.FeedTemperature.GetValue("C")
matrix(2, 1) = HeatCooler1.ProductTemperature.GetValue("C")
Set HeatCooler2 = simCase.Flowsheet.Operations.ITEM("E2-SR")
matrix(0, 2) = HeatCooler2.Duty.GetValue("kW")
matrix(1, 2) = HeatCooler2.FeedTemperature.GetValue("C")
matrix(2, 2) = HeatCooler2.ProductTemperature.GetValue("C")

'OBTAINING LNG UA
Set LNG1 = simCase.Flowsheet.Operations.ITEM("LNG-102")
matrix(0, 3) = LNG1.UA.GetValue("kJ/C-s")
matrix(1, 3) = LNG1.MinApproach.GetValue("C")

'VAPOUR FRACTION INLET FIRST COMPRESSOR
Set pstream = simCase.Flowsheet.MaterialStreams.ITEM("SR-6")
matrix(2, 3) = pstream.VapourFractionValue

RESULTS = matrix

End Function
```

APPENDIX 3: VBA Macro for MFC process – Liquefaction Loop

```
Public Function RESULTS(HP_LR As Double, LP_LR As Double, Xch4_LR As Double, Xc2h4_LR As Double, Flowrate_LR As Double) As Variant

Dim hyApp As HYSYS.Application
Dim simCase As SimulationCase
Dim pstream As ProcessStream
Dim compositions(5) As Variant
Dim Work1 As Object, Work2 As Object
Dim HeatCooler1 As Object
Dim LNG1 As Object
Dim matrix(2, 2) As Variant

'LOADING HYSYS SIMULATION CASE
Set hyApp = CreateObject("HYSYS.Application")
hyApp.Visible = True
hyApp.SimulationCases.Open ("I:\MFC simulation\MIN CAPEX\MFC_MINCAPEX_Final.hsc")
Set simCase = hyApp.ActiveDocument

compositions(0) = Xch4_LR
compositions(1) = 0
compositions(2) = 1 - Xch4_LR - Xc2h4_LR
compositions(3) = 0
compositions(4) = Xc2h4_LR
compositions(5) = 0

'READ DATA FROM FUNCTION ARGUMENT TO SUBCOOLING LOOP

'SUBCOOLING REFRIGERANT COMPOSITION AND FLOWRATE
Set pstream = simCase.Flowsheet.MaterialStreams.ITEM("LR-2")
pstream.ComponentMolarFraction.Values = compositions
pstream.MolarFlowValue = Flowrate_LR

'HIGH PRESSURE
Set pstream = simCase.Flowsheet.MaterialStreams.ITEM("LR-7")
pstream.PressureValue = HP_LR

'LOW PRESSURE
Set pstream = simCase.Flowsheet.MaterialStreams.ITEM("LR-4")
pstream.PressureValue = LP_LR

'SIMULATION RESULTS

'OBTAINING COMPRESSOR WORKS
Set Work1 = simCase.Flowsheet.Operations.ITEM("K1-LR")
matrix(0, 0) = Work1.Energy.GetValue("kW")
Set Work2 = simCase.Flowsheet.Operations.ITEM("K2-LR")
matrix(1, 0) = Work2.Energy.GetValue("kW")

'OBTAINING COOLER DATA
Set HeatCooler1 = simCase.Flowsheet.Operations.ITEM("E1-LR")
matrix(0, 1) = HeatCooler1.Duty.GetValue("kW")
matrix(1, 1) = HeatCooler1.FeedTemperature.GetValue("C")
matrix(2, 1) = HeatCooler1.ProductTemperature.GetValue("C")

'OBTAINING LNG UA
Set LNG1 = simCase.Flowsheet.Operations.ITEM("LNG-101")
matrix(0, 2) = LNG1.UA.GetValue("kJ/C-s")
matrix(1, 2) = LNG1.MinApproach.GetValue("C")

'VAPOUR FRACTION INLET FIRST COMPRESSOR
Set pstream = simCase.Flowsheet.MaterialStreams.ITEM("LR-5")
matrix(2, 2) = pstream.VapourFraction

RESULTS = matrix

End Function
```

APPENDIX 4: VBA Macro for MFC process – Precooling Loop

```
Public Function RESULTS(HP_PR As Double, LP_PR As Double, Xc2h4_PR As Double, Xc3h8_PR As Double, Flowrate_PR As Double) As Variant

Dim hyApp As HYSYS.Application
Dim simCase As SimulationCase
Dim pstream As ProcessStream
Dim compositions(5) As Variant
Dim Work1 As Object, Work2 As Object
Dim HeatCooler1 As Object, HeatCooler2 As Object
Dim LNG1 As Object
Dim matrix(2, 3) As Variant

'LOADING HYSYS SIMULATION CASE
Set hyApp = CreateObject("HYSYS.Application")
hyApp.Visible = True
hyApp.SimulationCases.Open ("I:\MFC simulation\MIN CAPEX\MFC_MINCAPEX_Final.hsc")
Set simCase = hyApp.ActiveDocument

compositions(0) = 0
compositions(1) = 0
compositions(2) = Xc3h8_PR
compositions(3) = 0
compositions(4) = Xc2h4_PR
compositions(5) = 1 - Xc3h8_PR - Xc2h4_PR

'READ DATA FROM FUNCTION ARGUMENT TO SUBCOOLING LOOP

'SUBCOOLING REFRIGERANT COMPOSITION AND FLOWRATE
Set pstream = simCase.Flowsheet.MaterialStreams.ITEM("PR-1")
pstream.ComponentMolarFraction.Values = compositions
pstream.MolarFlowValue = Flowrate_PR

'HIGH PRESSURE
Set pstream = simCase.Flowsheet.MaterialStreams.ITEM("PR-7")
pstream.PressureValue = HP_PR

'LOW PRESSURE
Set pstream = simCase.Flowsheet.MaterialStreams.ITEM("PR-3")
pstream.PressureValue = LP_PR

'SIMULATION RESULTS

'OBTAINING COMPRESSOR WORKS
Set Work1 = simCase.Flowsheet.Operations.ITEM("K1-PR")
matrix(0, 0) = Work1.Energy.GetValue("kW")
Set Work2 = simCase.Flowsheet.Operations.ITEM("K2-PR")
matrix(1, 0) = Work2.Energy.GetValue("kW")

'OBTAINING COOLER DATA
Set HeatCooler1 = simCase.Flowsheet.Operations.ITEM("E1-PR")
matrix(0, 1) = HeatCooler1.Duty.GetValue("kW")
matrix(1, 1) = HeatCooler1.FeedTemperature.GetValue("C")
matrix(2, 1) = HeatCooler1.ProductTemperature.GetValue("C")
Set HeatCooler2 = simCase.Flowsheet.Operations.ITEM("E2-PR")
matrix(0, 2) = HeatCooler2.Duty.GetValue("kW")
matrix(1, 2) = HeatCooler2.FeedTemperature.GetValue("C")
matrix(2, 2) = HeatCooler2.ProductTemperature.GetValue("C")

'OBTAINING LNG UA
Set LNG1 = simCase.Flowsheet.Operations.ITEM("LNG-100")
matrix(0, 3) = LNG1.UA.GetValue("kJ/C-s")
matrix(1, 3) = LNG1.MinApproach.GetValue("C")

'VAPOUR FRACTION INLET FIRST COMPRESSOR
Set pstream = simCase.Flowsheet.MaterialStreams.ITEM("PR-4")
matrix(2, 3) = pstream.VapourFraction

RESULTS = matrix

End Function
```

APPENDIX 5: MATLAB™ functions for equipment costing

Compressors:

```
function [C] = COST_Comp(W)

L=length(W);
B = zeros(L,1);
k = W/30000;
n = round(k);

    for i=1:L
        if k(i)-n(i)>0
            B(i,1)=((n(i)+1).*(580000+20000*((W(i,1)/(n(i)+1))^0.6)))/10^6;
        else
            B(i,1)=n(i).*(580000+20000*((W(i,1)/n(i))^0.6))/10^6;
        end
    end
    C = B.';

End
```

Coolers:

```
function [C] = COST_Cooler(Q,Tin,Tout)

L=length(Q);
C=zeros(1,L);
LMTD = ((Tin-25)-(Tout-20))./log((Tin-25)./(Tout-20));
U = 500;
A = (Q./LMTD).*(10^3/U);
k = A/1000;
n = round(k);

    for i=1:L
        if Q(1,i)>0
            if k(i)-n(i)>0
                C(1,i)=((n(i)+1).*(32000+70*(A(i)./(n(i)+1))^1.2))/10^6;
            else
                C(1,i)=n(i).*(32000+70*(A(i)./(n(i)))^1.2))/10^6;
            end
        else
            C(1,i)=0;
        end
    end

end

end
```

LNG Exchangers:

```
function [C] = COST_LNG(UA)

UA_MW_K = UA/(1000);
a = 958.357/73;
L = length(UA);
C = zeros(L,1);

    for i=1:L
        if UA_MW_K(i,1)>0
            C(i,1)=a*UA_MW_K(i,1);
        else
            C(i,1)=10^10;
        end
    end

end

end
```

APPENDIX 6: MATLAB™ functions for Hysys Link via VBA

C3MR

```
function [Results] = SimResults(HP_MR,LP_MR,ch4,c3h8,c2h4,IT_MR,Flowrate_MR)

excelObject=actxserver('Excel.Application');
excelObject.Workbooks.Open('I:\C3MR simulation\MINCAPEX\MR_MINCAPEXStudy.xlsm');
Matrix = excelObject.Run('RESULTS',HP_MR,LP_MR,ch4,c3h8,c2h4,IT_MR,Flowrate_MR);
Results = cell2mat(Matrix);
system('taskkill /F /IM EXCEL.exe');

end
```

MFC - Subcooling

```
function [Results] = SimResults_SR(HP_LR,LP_LR,Xch4_LR,Xn2_LR,Flowrate_LR)

excelObject=actxserver('Excel.Application');
excelObject.Workbooks.Open('I:\MFC simulation\MIN CAPEX\SR_MINCAPEXOptimization.xlsm');
Matrix = excelObject.Run('RESULTS',HP_LR,LP_LR,Xch4_LR,Xn2_LR,Flowrate_LR);
Results = cell2mat(Matrix);
system('taskkill /F /IM EXCEL.EXE');

end
```

MFC - Liquefaction

```
function [Results] = SimResults_LR(HP_LR,LP_LR,Xch4_LR,Xc2h4_LR,Flowrate_LR)

excelObject=actxserver('Excel.Application');
excelObject.Workbooks.Open('I:\MFC simulation\MIN CAPEX\LR_MINCAPEXOptimization.xlsm');
Matrix = excelObject.Run('RESULTS',HP_LR,LP_LR,Xch4_LR,Xc2h4_LR,Flowrate_LR);
Results = cell2mat(Matrix);
system('taskkill /F /IM EXCEL.EXE');

end
```

MFC - Precooling

```
function [Results] = SimResults_PR(HP_LR,LP_LR,Xc2h4_LR,Xc3h8_LR,Flowrate_LR)

excelObject=actxserver('Excel.Application');
excelObject.Workbooks.Open('I:\MFC simulation\MIN CAPEX\PR_MINCAPEXOptimization.xlsm');
Matrix = excelObject.Run('RESULTS',HP_LR,LP_LR,Xc2h4_LR,Xc3h8_LR,Flowrate_LR);
Results = cell2mat(Matrix);
system('taskkill /F /IM EXCEL.EXE');

end
```

APPENDIX 7: MATLAB™ optimization functions for C3MR

OF₁ - CAPEX:

```
function [C] = MINCAPEX(X)

HP_MR = X(1);
LP_MR = X(2);
ch4 = X(3);
c3h8 = X(4);
c2h4 = X(5);
IT_MR = X(6);
Flowrate_MR = X(7);
Data = SimResults(HP_MR,LP_MR,ch4,c3h8,c2h4,IT_MR,Flowrate_MR);
MTA = Data(5,3:4);
y = Data(6,4);

    if MTA>3
        if y>=1
            CompressorWork = Data(1:6,1);
            CoolerDuty = Data(1,2:4);
            TempCoolerIn = Data(2,2:4);
            TempCoolerOut = Data(3,2:4);
            UA = Data(1:8,5);
            Comp = COST_Comp(CompressorWork);
            Cooler = COST_Cooler(CoolerDuty,TempCoolerIn,TempCoolerOut);
            LNG = COST_LNG(UA);
            C = (567.5/550.8)*(2.5*sum(Comp)+3.5*sum(Cooler))+sum(LNG);
        else
            C = 10^5;
        end
    else
        C = 10^5;
    End
end
```

OF₂ - OPEX:

```
function [C] = MINOPEX(X)

HP_MR = X(1);
LP_MR = X(2);
ch4 = X(3);
c3h8 = X(4);
c2h4 = X(5);
IT_MR = X(6);
Flowrate_MR = X(7);
Data = SimResults(HP_MR,LP_MR,ch4,c3h8,c2h4,IT_MR,Flowrate_MR);
MTA = Data(5,3:4);
y = Data(6,4);

    if MTA>3
        if y>=1
            CompressorWork = Data(1:6,1);
            CoolerDuty = Data(1,2:4);
            C = 460.95+(7884*3600/10^12)*(10.99*sum(CompressorWork)+0.40*sum(CoolerDuty));
        else
            C = 10^4;
        end
    else
        C = 10^4;
    end
end
```

OF3 - TAC:

```
function [C] = MINTAC(X)

HP_MR = X(1);
LP_MR = X(2);
ch4 = X(3);
c3h8 = X(4);
c2h4 = X(5);
IT_MR = X(6);
Flowrate_MR = X(7);
Data = SimResults(HP_MR,LP_MR,ch4,c3h8,c2h4,IT_MR,Flowrate_MR);
MTA = Data(5,3:4);
y = Data(6,4);

    if MTA>3
        if y>=1
            CompressorWork = Data(1:6,1);
            CoolerDuty = Data(1,2:4);
            TempCoolerIn = Data(2,2:4);
            TempCoolerOut = Data(3,2:4);
            UA = Data(1:8,5);
            Comp = COST_Comp(CompressorWork);
            Cooler = COST_Cooler(CoolerDuty,TempCoolerIn,TempCoolerOut);
            LNG = COST_LNG(UA);
            CAPEX = (567.5/550.8)*(2.5*sum(Comp)+3.5*sum(Cooler))+sum(LNG);
            OPEX = 460.95+(7884*3600/10^12)*(10.99*sum(CompressorWork)+0.40*sum(CoolerDuty));
            C = 0.1*CAPEX + OPEX;
        else
            C = 10^4;
        end
    else
        C = 10^4;
    end

end
```

APPENDIX 8: MATLAB™ optimization functions for MFC

OF₁ – CAPEX - Subcooling:

```
function [C] = MINCAPEX_SR(X)
HP_SR = X(1);
LP_SR = X(2);
Xch4_SR = X(3);
Xn2_SR = X(4);
Flowrate_SR = X(5);
Data = SimResults_SR(HP_SR,LP_SR,Xch4_SR,Xn2_SR,Flowrate_SR);
MTA = Data(2,4);
y = Data(3,4);
    if MTA>3
        if y>=1
            CompressorWork = Data(1:3,1);
            CoolerDuty = Data(1,2:3);
            TempCoolerIn = Data(2,2:3);
            TempCoolerOut = Data(3,2:3);
            UA = Data(1,4);
            Comp = COST_Comp(CompressorWork);
            Cooler = COST_Cooler(CoolerDuty,TempCoolerIn,TempCoolerOut);
            LNG = COST_LNG(UA);
            C = (567.5/550.8)*(2.5*sum(Comp)+3.5*sum(Cooler))+sum(LNG);
        else
            C = 10^3;
        end
    else
        C = 10^3;
    end
end
```

OF₁ – CAPEX - Liquefaction:

```
function [C] = MINCAPEX_LR(X)
HP_LR = X(1);
LP_LR = X(2);
Xch4_LR = X(3);
Xc2h4_LR = X(4);
Flowrate_LR = X(5);
Data = SimResults_LR(HP_LR,LP_LR,Xch4_LR,Xc2h4_LR,Flowrate_LR);
MTA = Data(2,3);
y = Data(3,3);
    if MTA>3
        if y>=1
            CompressorWork = Data(1:2,1);
            CoolerDuty = Data(1,2);
            TempCoolerIn = Data(2,2);
            TempCoolerOut = Data(3,2);
            UA = Data(1,3);
            Comp = COST_Comp(CompressorWork);
            Cooler = COST_Cooler(CoolerDuty,TempCoolerIn,TempCoolerOut);
            LNG = COST_LNG(UA);
            C = (567.5/550.8)*(2.5*sum(Comp)+3.5*sum(Cooler))+sum(LNG);
        else
            C = 10^5;
        end
    else
        C = 10^5;
    end
end
```

OF₁ – CAPEX - Precooling:

```
function [C] = MINCAPEX_PR(X)
HP_PR = X(1);
LP_PR = X(2);
Xc2h4_PR = X(3);
Xc3h8_PR = X(4);
```

```

Flowrate_PR = X(5);
Data = SimResults_PR(HP_PR,LP_PR,Xc2h4_PR,Xc3h8_PR,Flowrate_PR);
MTA = Data(2,4);
y = Data(3,4);
    if MTA>3
        if y>=1
            CompressorWork = Data(1:2,1);
            CoolerDuty = Data(1,2:3);
            TempCoolerIn = Data(2,2:3);
            TempCoolerOut = Data(3,2:3);
            UA = Data(1,4);
            Comp = COST_Comp(CompressorWork);
            Cooler = COST_Cooler(CoolerDuty,TempCoolerIn,TempCoolerOut);
            LNG = COST_LNG(UA);
            C = (567.5/550.8)*(2.5*sum(Comp)+3.5*sum(Cooler))+sum(LNG);
        else
            C = 10^3;
        end
    else
        C = 10^3;
    end
end

```

OF2 – OPEX - Subcooling:

```

function [C] = MINOPEX_SR(X)
HP_SR = X(1);
LP_SR = X(2);
Xch4_SR = X(3);
Xn2_SR = X(4);
Flowrate_SR = X(5);
Data = SimResults_SR(HP_SR,LP_SR,Xch4_SR,Xn2_SR,Flowrate_SR);
MTA = Data(2,4);
y = Data(3,4);
    if MTA>3
        if y>=1
            CompressorWork = Data(1:3,1);
            CoolerDuty = Data(1,2:3);
            C = (7884*3600/10^12)*(10.99*sum(CompressorWork)+0.40*sum(CoolerDuty));
        else
            C = 10^3;
        end
    else
        C = 10^3;
    end
end

```

OF2 – OPEX - Liquefaction:

```

function [C] = MINOPEX_LR(X)
HP_LR = X(1);
LP_LR = X(2);
Xch4_LR = X(3);
Xc2h4_LR = X(4);
Flowrate_LR = X(5);
Data = SimResults_LR(HP_LR,LP_LR,Xch4_LR,Xc2h4_LR,Flowrate_LR);
MTA = Data(2,3);
y = Data(3,3);
    if MTA>3
        if y>=1
            CompressorWork = Data(1:2,1);
            CoolerDuty = Data(1,2);
            C = (7884*3600/10^12)*(10.99*sum(CompressorWork)+0.40*sum(CoolerDuty));
        else
            C = 10^3;
        end
    else
        C = 10^3;
    end
end

```

OF₂ – OPEX - Precooling:

```
function [C] = MINOPEX_PR(X)
HP_PR = X(1);
LP_PR = X(2);
Xc2h4_PR = X(3);
Xc3h8_PR = X(4);
Flowrate_PR = X(5);
Data = SimResults_PR(HP_PR,LP_PR,Xc2h4_PR,Xc3h8_PR,Flowrate_PR);
MTA = Data(2,4);
y = Data(3,4);
    if MTA>3
        if y>=1
            CompressorWork = Data(1:2,1);
            CoolerDuty = Data(1,2:3);
            C = 460.95+(7884*3600/10^12)*(10.99*sum(CompressorWork)+0.40*sum(CoolerDuty));
        else
            C = 10^3;
        end
    else
        C = 10^3;
    end
end
```

OF₃ – TAC - Subcooling:

```
function [C] = MINTAC_SR(X)
HP_SR = X(1);
LP_SR = X(2);
Xch4_SR = X(3);
Xn2_SR = X(4);
Flowrate_LR = X(5);
Data = SimResults_SR(HP_SR,LP_SR,Xch4_SR,Xn2_SR,Flowrate_SR);
MTA = Data(2,4);
y = Data(3,4);
    if MTA>3
        if y>=1
            CompressorWork = Data(1:3,1);
            CoolerDuty = Data(1,2:3);
            TempCoolerIn = Data(2,2:3);
            TempCoolerOut = Data(3,2:3);
            UA = Data(1,4);
            Comp = COST_Comp(CompressorWork);
            Cooler = COST_Cooler(CoolerDuty,TempCoolerIn,TempCoolerOut);
            LNG = COST_LNG(UA);
            CAPEX = (567.5/550.8)*(2.5*sum(Comp)+3.5*sum(Cooler))+sum(LNG);
            OPEX = (7884*3600/10^12)*(10.99*sum(CompressorWork)+0.40*sum(CoolerDuty));
            C = 0.1*CAPEX + OPEX;
        else
            C = 10^3;
        end
    else
        C = 10^3;
    end
end
```

OF₃ – TAC - Liquefaction:

```
function [C] = MINTAC_LR(X)
HP_LR = X(1);
LP_LR = X(2);
Xch4_LR = X(3);
Xc2h4_LR = X(4);
Flowrate_LR = X(5);
Data = SimResults_LR(HP_LR,LP_LR,Xch4_LR,Xc2h4_LR,Flowrate_LR);
MTA = Data(2,3);
y = Data(3,3);
    if MTA>3
        if y>=1
            CompressorWork = Data(1:2,1);
```

```

CoolerDuty = Data(1,2);
TempCoolerIn = Data(2,2);
TempCoolerOut = Data(3,2);
UA = Data(1,3);
Comp = COST_Comp(CompressorWork);
Cooler = COST_Cooler(CoolerDuty,TempCoolerIn,TempCoolerOut);
LNG = COST_LNG(UA);
CAPEX = (567.5/550.8)*(2.5*sum(Comp)+3.5*sum(Cooler))+sum(LNG);
OPEX = (7884*3600/10^12)*(10.99*sum(CompressorWork)+0.40*sum(CoolerDuty));
C = 0.1*CAPEX + OPEX;
else
C = 10^3;
end
else
C = 10^3;
end
end
end

```

OF₃ – TAC - Precooling:

```

function [C] = MINOPEX_PR(X)
HP_PR = X(1);
LP_PR = X(2);
Xc2h4_PR = X(3);
Xc3h8_PR = X(4);
Flowrate_PR = X(5);
Data = SimResults_PR(HP_PR,LP_PR,Xc2h4_PR,Xc3h8_PR,Flowrate_PR);
MTA = Data(2,4);
y = Data(3,4);
if MTA>3
if y>=1
CompressorWork = Data(1:2,1);
CoolerDuty = Data(1,2:3);
TempCoolerIn = Data(2,2:3);
TempCoolerOut = Data(3,2:3);
UA = Data(1,4);
Comp = COST_Comp(CompressorWork);
Cooler = COST_Cooler(CoolerDuty,TempCoolerIn,TempCoolerOut);
LNG = COST_LNG(UA);
CAPEX = (567.5/550.8)*(2.5*sum(Comp)+3.5*sum(Cooler))+sum(LNG);
OPEX = 460.95+(7884*3600/10^12)*(10.99*sum(CompressorWork)+0.40*sum(CoolerDuty));
C = 0.1*CAPEX + OPEX;
else
C = 10^3;
end
else
C = 10^3;
end
end
end

```